



## MODEL D30-32 DIESEL HAMMER

- \* *Fuel injection designed by APE engineers.*
- \* *Hardened piston needs no high maintenance wear rings.*
- \* *Direct drive available for maximum production on steel piles.*
- \* *Fuel pump mounted where heat will not harm it.*
- \* *Variable mechanical cam fuel pump – no air pistons or rings.*
- \* *Optional hydraulic variable fuel remote control.*
- \* *Heavy duty trip system for years of fault free operation.*
- \* *Chrome rings for super long life.*
- \* *Low maintenance and extremely low parts pricing.*
- \* *German design at a reasonable price.*



APE HOLLAND

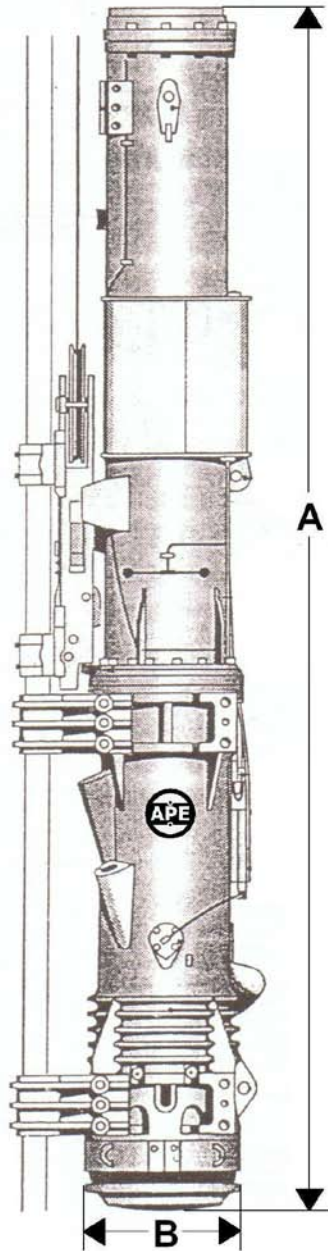

Technical Data		
Impact weight (piston)	kg.	3.000
Energy per blow	kNm	103 - 48
Number of blows	Min <sup>-1</sup>	36 - 52
Consumption		
Diesel oil	l/h	10
Lubricant	l/h	1
Tank capacity		
Diesel oil tank	l	67
Lube tank	l	19
Max. rope diameter for deflector sheave of tripping device.	mm	22
Weight		
Tripping device	kg.	180
Diesel pile hammer	kg.	6.799
<b>Max. inclined pile driving without / with extension</b>		1:5 / 1:1
Dimensions		
A. Length of diesel hammer without extension	mm.	5.450
B. Outer diameter of impact block	mm.	560
C. Standard distance from center of diesel hammer up to the face of the lead.	mm.	435
D. Center of hammer to center of threads for guide jaw bolts.	mm.	235
E. Center of hammer to pump guard.	mm.	405
F. Width for connection of guide jaws.	mm.	540
G. Width of diesel hammer	mm.	640
H. Depth of diesel hammer	mm.	715

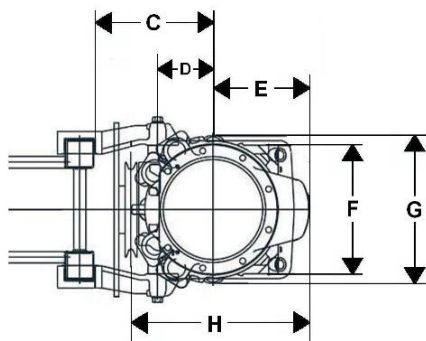

APE Holland BV, P.O. Box 34, 7990 AA Dwingeloo, The Netherlands  
 Tel.: +31(0) 593 54 08 91, Fax: +31(0) 593 54 27 84, [www.apeholland.com](http://www.apeholland.com), [info@apeholland.com](mailto:info@apeholland.com)